

### 7.3 Furlex 104S-404S (2014-) & Furlex Electric (2018-)

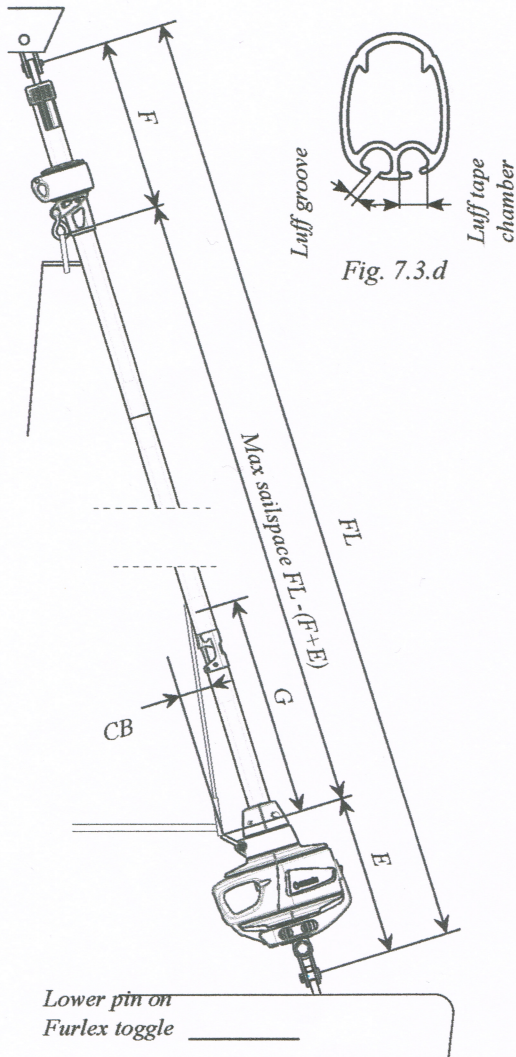

Fig. 7.3.a

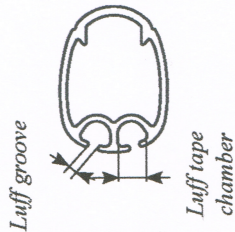

Fig. 7.3.d

Sails with a luff considerably shorter (more than 500 mm) than the maximum permissible must be fitted with a permanent head pendant. The total luff length including pendant should be just less than the "Max. sail space" dimension.

A too short luff length (including head pendant) can result in "halyard wrap" which may cause severe damage to the forestay, and put the entire rig at risk. For more information please refer to "Sail information" in the relevant Furlex manual.

min. 50 mm

Fig. 7.3.b

Furlex 104S/204S Mk2/304S Mk2/404S halyard swivel.

If "F" measurement is > specified (sail is made too short) there is a risk of the halyard shackle shafing the luff extrusion.

Always check clearance. Add a pendant between sail and halyard swivel or a soft shackle between HMPE loop in the halyard swivel and the halyard shackle. A too short luff length (including head pendant) can also result in "halyard wrap" which may cause severe damage to the forestay, and put the entire rig at risk. For more information please refer to "Sail information" in the relevant Furlex manual.

Fig. 7.3.c

Furlex Type/Serie	Section dimension	Luff groove	Max. space available in chamber	Max. luff tape	Cut-back	Cut-back height	Maximum sail space FL-(F+E) (Measurement calculated from existing forestay length: FL).		
							F	E	F+E
		mm	mm	mm	CB mm	G mm	F mm	E mm	F+E mm
104S Ø 4 & 5	30/20	2.75	Ø 6	Ø 5	60	1100	440	205	645
104S Ø 6	30/20	2.75	Ø 6	Ø 5	60	1100	440	220	660
204S Ø 6	35/25	3.0	Ø 6	Ø 5	60	1100	425	265	690
204S Ø 7	35/25	3.0	Ø 6	Ø 5	60	1100	425	265	690
204S Ø 8	35/25	3.0	Ø 6	Ø 5	60	1100	425	275	700
304S Ø 8	42/31	3.0	Ø 7	Ø 6.5	60	1100	430	310	740
304S Ø 10	42/31	3.0	Ø 7	Ø 6.5	60	1100	530	315	845
404S Ø 12	52/38	3.0	Ø 8	Ø 6.5	80	1100	630	390	1020
404S Ø 14	52/38	3.0	Ø 8	Ø 6.5	80	1100	630	410	1040

$FL = 14560 \text{ mm}$   
 $B = 13860 \text{ mm}$

**Head deduction (F) Furlex 204S-304S Mk2 Halyard swivel (2018-)**

Furlex type	F	F+E
204S Ø 6	485	750
204S Ø 7	485	750
204S Ø 8	485	760
304S Ø 8	490	800
304S Ø 10	590	905

