

MAINSAIL MEASUREMENT FORM

We require the following information and measurements to enable us to ensure a perfect fit for your new sail. Please note that if asked for max dimensions or max hoist, we will deduct a suitable amount for stretch. Do not measure sails using a rope. It is advisable to use a long fiberglass tape.

CUSTOMER NAME:

BOAT TYPE: RIG TYPE: FRACTIONAL OR MASTHEAD

HOW TO COMPLETE THIS FORM

Either measure existing sail or enter rig dimensions

EXISTING SAIL

Pull sail tight for measurement. Ensure each length is a straight line measurement from head to tack and clew.

MAX LUFF	MAX LEECH	MAX FOOT
m	m	m

MEASURE YOUR RIG

Attach tape measure to mainsail halyard and maximum hoist to top block.

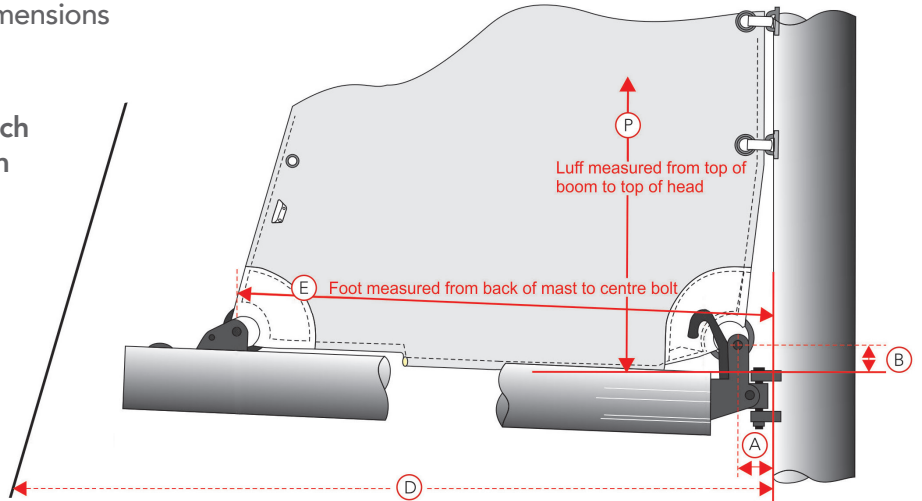

1. To measure max Luff: (P) (we will deduct stretch) m
Take measurement to top of boom for Luff.

2. To measure max Leech: (we will deduct stretch) m
Take measurement to desired clew position or black band.
(Only necessary if boom end needs to be raised to allow for sprayhood or other).

3. To measure Foot (E) m
Drop halyard, remove tape measure and measure length of boom from back of mast to black band or clew position.

4. To measure Backstay distance (D) m
Measure from back of mast to backstay.

5. To measure Mast Bend. mm
With the main halyard pulled tight down to the intersection of boom and mast, look up the mast to determine the mast bend. Estimate the distance between halyard and aft face of mast about 1/2 way up and record this as the Mast Bend Measurement.

TACK DETAILS (refer to diagram above)

1. Tack Back (A) Measure from back of mast to centre of tack pin. mm

2. Tack Up (B) Measure from top of boom to centre of tack pin. mm

3. Sail insertion height. From top of boom to bottom of mast gate. mm

CLEW DETAILS (please tick option 1, 2 or 3)

1. Standard is stainless steel ring only

2. S/S ring with velcro strop to go around boom

3. S/S ring with clew slide for boom groove. Specify slide number and dimensions as per diagram on page 2

MAINSAIL MEASUREMENT FORM

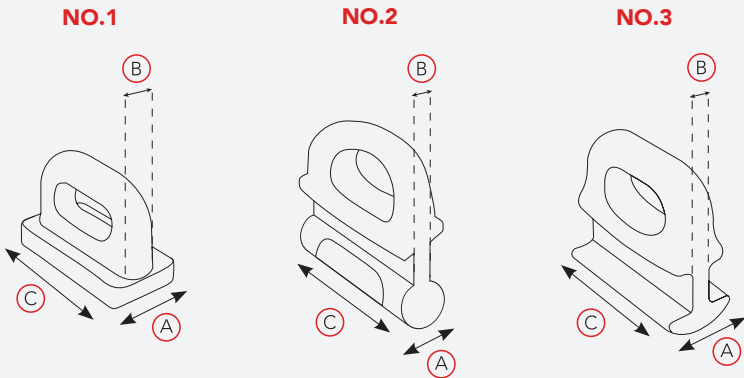

See attached Photos and instructions of Harken

LUFF ATTACHMENT

Specify luff slide style 1,2,3 or other (see diagrams) OR provide measurements and photo.

Existing luff slides: Part Number.

Measurements of existing luff slide

(A) Width	(B) Neck	(C) Length
<input type="text" value="mm"/>	<input type="text" value="mm"/>	<input type="text" value="mm"/>

Or Measurements of mast track

(A) Internal Width	(B) Internal Depth	(C) Track Opening
<input type="text" value="mm"/>	<input type="text" value="mm"/>	<input type="text" value="mm"/>

REEF HEIGHTS

Reef heights will be incorporated in sail design. Only if specific heights are required, please specify.

Top of boom to Reef 1	<input type="text" value="m"/>
Top of boom to Reef 2	<input type="text" value="m"/>
Top of boom to Reef 3	<input type="text" value="m"/>

Please specify horizontal lengths from back of mast if reefing blocks in the boom are non-removable.

REEF FINISHING DETAILS (please tick)

1. Standard pressed eye	<input type="checkbox"/>
Single line reefing can be fed through each cringle	
2. Standard pressed eye at leech	<input type="checkbox"/>
Dogbone strop at luff for ramshorn	
3. Webbing Loop to attach block for single line reefing.	<input type="checkbox"/>
Blocks can go either at LUFF, LEECH or BOTH	
If just at luff then standard pressed eye will be put at leech.	

(please circle and indicate which side)

Reef 1 STB

Reef 1	LEECH	LUFF	PRT /STB
Reef 2	LEECH	LUFF	PRT /STB
Reef 3	LEECH	LUFF	PRT /STB

FOOT FINISHING

1. Loose foot only	<input type="checkbox"/>
(clew side already in place) (please tick)	
2. Loose foot with clew side (please tick)	<input type="checkbox"/>
3. Bolt rope.	<input type="text" value="mm"/>
(please indicate size in mm)	

HOW TO MEASURE FOR A FURLING MAINSAIL

Attach tape measure to bottom of head swivel and pull to max hoist and lock halyard off.

1. Max Luff: Measure to tack hook or shackle in mast.	
2. Max Leech: Make sure boom is clear of bimini or set boom as you would sailing. Measure to max outhaul position of block.	
3. Outhaul: Secure measure to tack hook or shackle. Run tape along boom and measure to max outhaul position.	
4. Luff tape diameter	<input type="text" value="mm"/>
5. Clew block or Standard clew ring (circle)	