

Mainsail: 8000533 Daniel-1 JeanneauSO37 Tri-radialmain.des Fareast Sails

Design Info
=====

Design File:
\\NAS\Engineering files\Queenie-Customer Order\Fareast Sails\2024 Orders\Need to be Confirmed\8000533 Daniel J

Initial Design Date: 11/6/2024
Boat:
Jeanneau Sun Odyssey 37
Client:
Fareast Sails

Comments:

Design Data
=====

Main

Measurements

Luff geodesic: 11.533m
Leech geodesic: 12.226m
Foot geodesic: 4.197m
Head geodesic: 0.133m
Upper width (MUW): 0.816m
Three-quarter width (MTW): 1.499m
Half width (MHW): 2.655m
Quarter width (MQW): 3.520m
Foot median: 11.802m
ORC Mainsail area: 28.368m?
Surface area: 29.158m?
Clew height: 0.000m
Mast rake: 0.150m

Battens

Position	Length	Roach	Angle	Luff	Leech	Full
80.000%	1.306m	0.285m	71.918?	9.223m	9.734m	Full
60.000%	2.305m	0.409m	71.918?	6.917m	7.300m	Full
40.000%	3.082m	0.365m	71.918?	4.612m	4.867m	Full
20.000%	3.687m	0.210m	71.918?	2.307m	2.433m	Full

Reefing Points

1, Luff: 1.407m ; Leech: 1.449m ; Offset: 0.000m ; Number Eyelets: 0
2, Luff: 3.034m ; Leech: 3.160m ; Offset: 0.000m ; Number Eyelets: 0

Draft Stripes

1, Luff: 7.611m ; Leech: 7.891m ;
2, Luff: 3.806m ; Leech: 3.892m ;

Luff Slides

1, Position: 0.903m
2, Position: 1.726m
3, Position: 2.927m
4, Position: 3.774m
5, Position: 5.380m
6, Position: 6.149m
7, Position: 7.686m
8, Position: 8.454m
9, Position: 9.993m
10, Position: 10.763m

Luff Curve

		Fanned Luff (@ 5.00% [0.209m])	Before BSeam
11.533m,	0.000m	100% (11.533m) :	0.000m
10.368m,	-0.014m	90% (10.380m) :	0.036m
9.226m,	-0.025m	80% (9.226m) :	0.070m
8.062m,	-0.033m	70% (8.073m) :	0.096m
6.920m,	-0.037m	60% (6.920m) :	0.111m
5.212m,	-0.039m	50% (5.766m) :	0.114m
3.460m,	-0.034m	40% (4.613m) :	0.106m
1.832m,	-0.021m	30% (3.460m) :	0.087m
0.000m,	0.000m	20% (2.307m) :	0.061m
		10% (1.153m) :	0.028m
		0% (0.000m) :	0.000m

Mainsail: 8000533 Daniel-1 JeanneauSO37 Tri-radialmain.des Fareast Sails

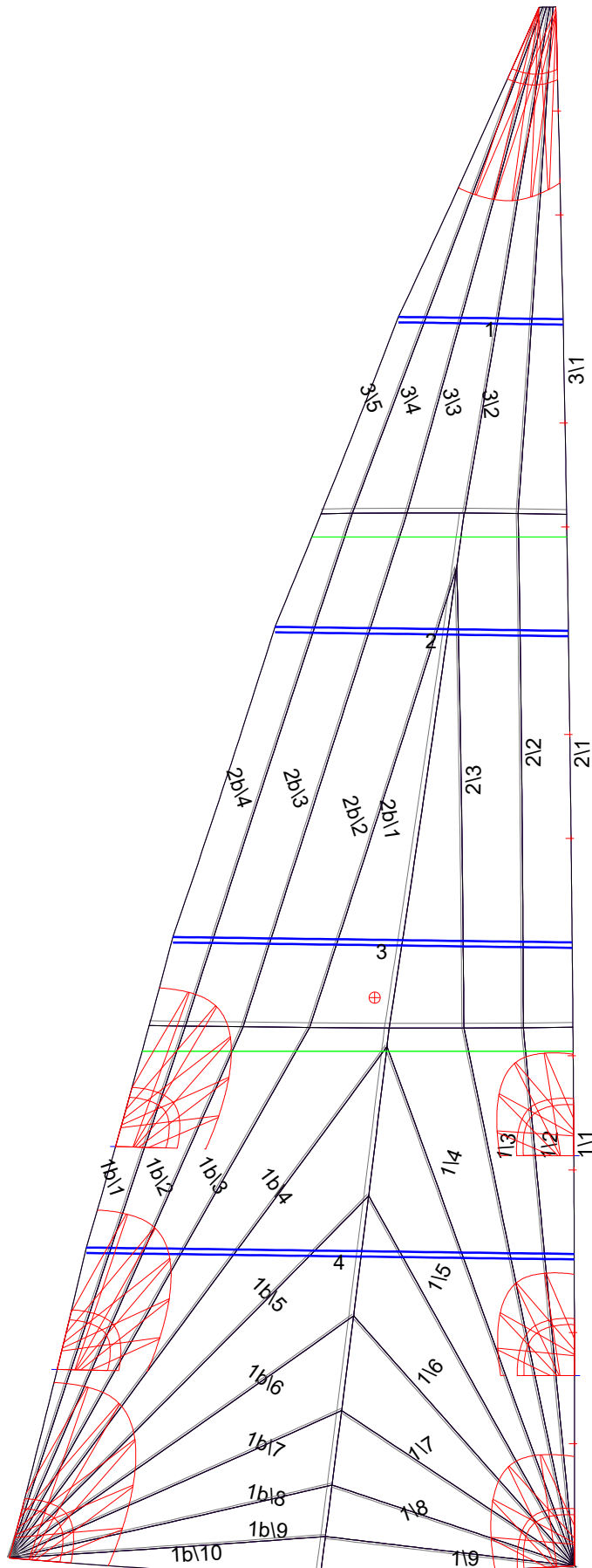

Seam Allowances

Zone:	Split	Radial	Cross
Zone: 1/a	0.035m	0.015m	0.035m
Zone: 1/b	0.035m	0.015m	0.035m
Zone: 2/a	0.035m	0.015m	0.035m
Zone: 2/b	0.035m	0.015m	0.035m
Zone: 3	0.035m	0.015m	0.035m

Edge Excesses

Sail:	Luff	Leech	Foot
	0.000m	0.000m	0.000m

Total Seam Lengths (m)

Horizontal	5.19
Radial/Vertical	90.53
Bi-Radial Split	8.23

Materials

Material	Area (m ²)	Panels
Material 2	18.63	1\4, 1\6, 1\8, 1\9, 1b\1 1b\2, 1b\3, 1b\4, 1b\5, 1b\7 1b\9, 1b\10, 2b\1, 2b\2, 2b\3 2b\4, 3\1, 3\2, 3\3, 3\4 3\5
Material 3	10.57	1\1, 1\2, 1\3, 1\5, 1\7 1b\6, 1b\8, 2\1, 2\2, 2\3