

# Mainsail: 8000517 Richard fullbattmain.des

Design Info  
=====

Design File:  
\\NAS\Engineering files\Queenie-Customer Order\Fareast Sails\2024 Orders\Need to be Confirmed\8000517 Richard r

Initial Design Date: 5/6/2024  
Boat:

Comments:

Client:

Design Data  
=====

## Main

### Measurements

Luff geodesic:	7.564m
Leech geodesic:	7.989m
Foot geodesic:	2.792m
Head geodesic:	0.102m
Upper width (MUW):	0.542m
Three-quarter width (MTW):	0.980m
Half width (MHW):	1.714m
Quarter width (MQW):	2.309m
Foot median:	7.685m
ORC Mainsail area:	12.194m?
Surface area:	12.440m?
Clew height:	0.100m
Mast rake:	0.000m

### Battens

Position	Length	Roach	Angle	Luff	Leech	Full
80.000%	0.858m	0.158m	71.806?	6.051m	6.372m	Full
60.000%	1.480m	0.205m	71.806?	4.544m	4.779m	Full
40.000%	1.995m	0.175m	71.806?	3.037m	3.186m	Full
20.000%	2.423m	0.096m	71.806?	1.530m	1.593m	Full

### Reefing Points

1, Luff: 0.922m ; Leech: 0.956m ; Offset: 0.000m ; Number Eyelets: 2  
 2, Luff: 1.928m ; Leech: 1.997m ; Offset: 0.000m ; Number Eyelets: 2

### Draft Stripes

1, Luff: 2.495m ; Leech: 2.507m ;  
 2, Luff: 4.991m ; Leech: 5.143m ;

### Luff Slides

1, Position: 0.756m  
 2, Position: 2.267m  
 3, Position: 3.779m  
 4, Position: 5.291m  
 5, Position: 6.805m

### Luff Curve

		Fanned Luff (@ 5.00% [0.139m])	Before BSeam
7.564m,	0.000m	100% (7.564m) :	-0.000m 0.000m
6.621m,	-0.017m	90% (6.808m) :	0.011m 0.030m
5.673m,	-0.030m	80% (6.051m) :	0.020m 0.055m
4.722m,	-0.035m	70% (5.295m) :	0.025m 0.073m
3.782m,	-0.036m	60% (4.538m) :	0.027m 0.083m
2.818m,	-0.033m	50% (3.782m) :	0.026m 0.087m
1.891m,	-0.027m	40% (3.026m) :	0.025m 0.084m
0.943m,	-0.015m	30% (2.269m) :	0.020m 0.074m
0.000m,	0.000m	20% (1.513m) :	0.015m 0.055m
		10% (0.756m) :	0.007m 0.028m
		0% (0.000m) :	0.000m 0.000m

# Mainsail: 8000517 Richard fullbattmain.des

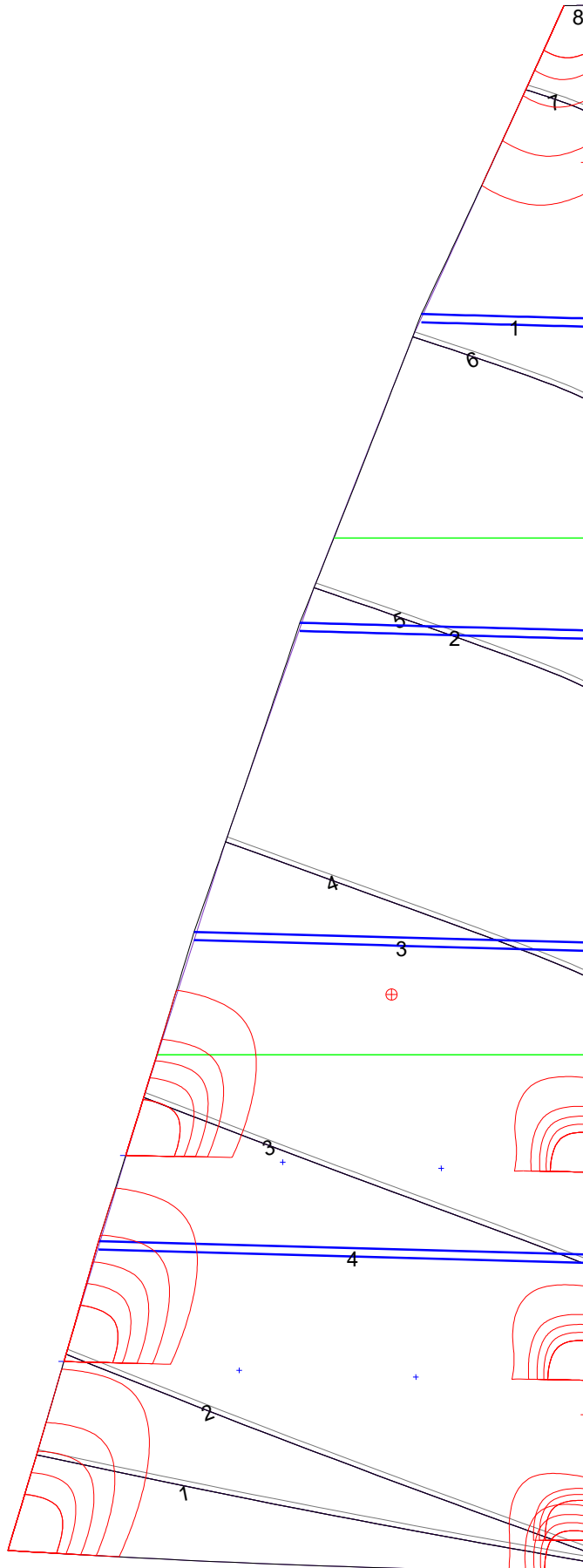

Seam Allowances			
Zone: 1	Split	Radial	Cross
	0.000m	0.000m	0.025m

Edge Excesses			
Sail:	Luff	Leech	Foot
	0.000m	0.000m	0.000m

Total Seam Lengths (m)

Horizontal	12.49
Radial/Vertical	0.00
Bi-Radial Split	0.00

Materials

Material	Area (m <sup>2</sup> )	Panels
Material 1	12.42	1,2,3,4,5 6,7,8