

Genoa: 7000121 Kurt Corsair F-31R jib V2.des

Design Info

=====

Design File:

F:\Dropbox\Dropbox-20221019\Dropbox20221213\Dropbox\Fareast Sails\2023 Order\Need Confrim Order\7000121 Ku

Initial Design Date: 3/2/2023

Boat:

Corsair F-31R

Client:

Comments:

LP=11.76ft, furl jib, Tri-radial cut

luff=32.75ft, leech=30.3ft, foot=12.67ft

3 vertical batten, 10inch roach at top batten

uv cover on leech and foot

Design Data

=====

Genoa

Measurements

Luff geodesic:	9.982m
Leech geodesic:	9.236m
Foot geodesic:	3.861m
Headboard width:	0.030m
Luff perpendicular (HLP):	3.584m
Upper width (HUW):	0.617m
Three-quarter width (HTW):	1.128m
Half width (HHW):	1.985m
Quarter width (HQW):	2.782m
Foot median:	9.519m
ORC Headsail area:	19.131m ²
IRC Headsail area:	19.254m ²
Surface area:	19.449m ²
Forestay height:	12.954m
J:	3.554m

Battens

Position	Length	Roach	Angle	Luff	Leech	Full
75.000%	1.400m	0.254m	157.640?	29.961m	6.882m	
50.679%	1.600m	0.193m	157.640?	67.529m	4.650m	
27.091%	1.600m	0.087m	157.640?	103.963m	2.486m	

Draft Stripes

1, Luff: 3.308m ; Leech: 2.688m ;
2, Luff: 6.610m ; Leech: 5.873m ;

Luff Curve

		Fanned Luff (@ 5.00% [0.189m])	Before BSeam
9.980m,	0.000m	100% (9.980m) :	0.000m
9.151m,	0.035m	90% (8.982m) :	-0.040m
8.233m,	0.063m	80% (7.985m) :	-0.072m
7.426m,	0.078m	70% (6.987m) :	-0.085m
6.487m,	0.084m	60% (5.989m) :	-0.085m
4.966m,	0.073m	50% (4.990m) :	-0.079m
3.243m,	0.050m	40% (3.992m) :	-0.067m
1.687m,	0.025m	30% (2.994m) :	-0.052m
0.000m,	0.000m	20% (1.996m) :	-0.036m
		10% (0.997m) :	-0.018m
		0% (0.000m) :	0.000m

Genoa: 7000121 Kurt Corsair F-31R jib V2.des

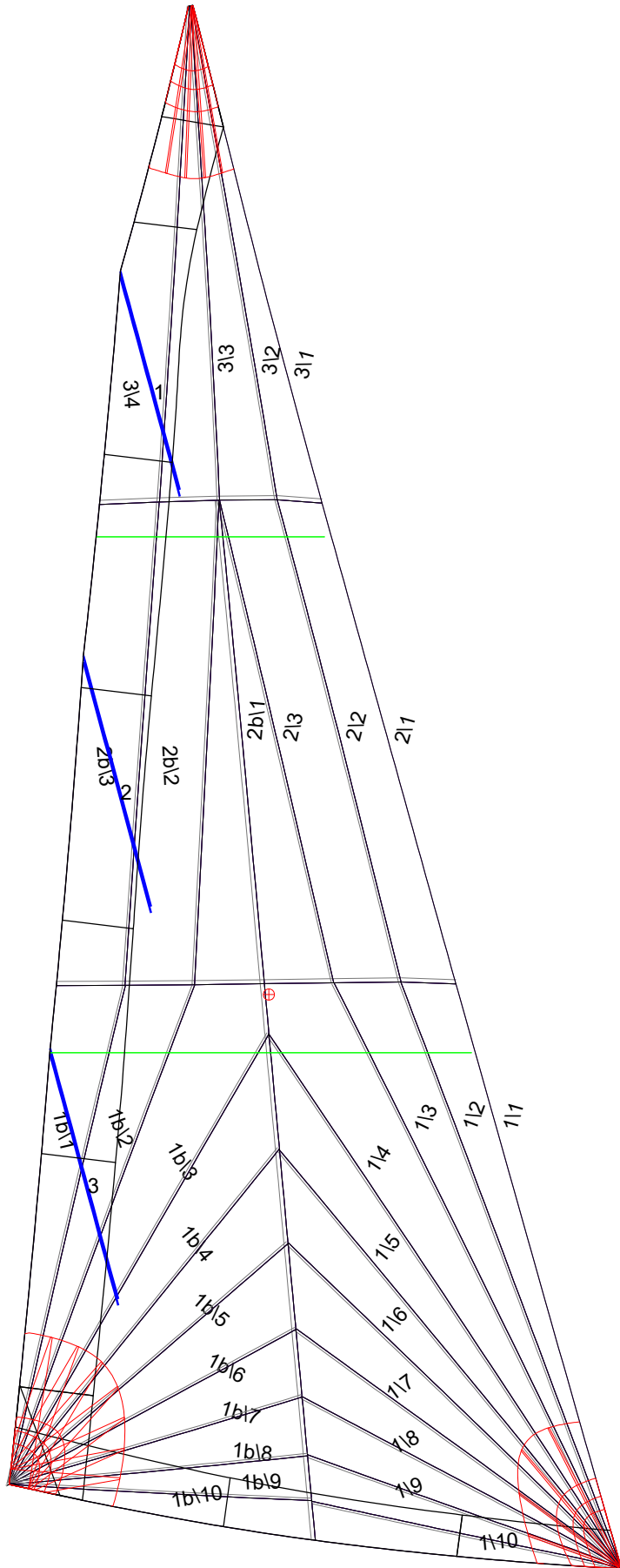

Seam Allowances

	Split	Radial	Cross
Zone: 1/a	0.025m	0.015m	0.025m
Zone: 1/b	0.025m	0.015m	0.025m
Zone: 2/a	0.025m	0.015m	0.025m
Zone: 2/b	0.025m	0.015m	0.025m
Zone: 3	0.025m	0.015m	0.025m
Cover 1	0.025m	0.025m	0.025m
Cover 2	0.025m	0.025m	0.025m
Cover 3	0.000m	0.000m	0.000m
Cover 4	0.000m	0.000m	0.000m

Edge Excesses

	Luff	Leech	Foot
Sail:	0.000m	0.000m	0.000m
Cover 0	0.070m	0.070m	0.070m
Cover 1	0.070m	0.070m	0.070m
Cover 2	0.000m	0.070m	0.070m
Cover 3	0.000m	0.070m	0.070m

Total Seam Lengths (m)

Horizontal	4.07
Radial/Vertical	71.06
Bi-Radial Split	6.64

Materials

Material	Area (m ²)	Panels
Material 1	19.48	1\1,1\2,1\3,1\4,1\5 1\6,1\7,1\8,1\9,1\10 1b\1,1b\2,1b\3,1b\4,1b\5 1b\6,1b\7,1b\8,1b\9,1b\10 2\1,2\2,2\3,2b\1,2b\2 2b\3,3\1,3\2,3\3,3\4