

# Mainsail: 7000102 Christian square top main V1.des Michael

## Design Info =====

Initial Design Date: 11/1/2023  
Boat:  
Pogo 40 square top mainsail  
Client:  
Michael

Design File:  
F:\Dropbox\Dropbox-20221019\Dropbox20221213\Dropbox\Fareast Sails\2023 Order\Need Confrim Order\7000102 C

Comments:  
comment: batten length to be re-confirmed, please check all battens placement,  
  
if you measured old sail, did you get some pic of old sail?

## Design Data =====

### Main

#### Measurements

Luff geodesic: 16.250m  
Leech geodesic: 16.900m  
Foot geodesic: 5.500m  
Head geodesic: 1.500m  
Upper width (MUW): 2.030m  
Three-quarter width (MTW): 3.001m  
Half width (MHW): 4.110m  
Quarter width (MQW): 4.885m  
Foot median: 16.520m  
ORC Mainsail area: 62.503m?  
Surface area: 64.572m?  
Clew height: 0.375m  
Mast rake: 0.000m

#### Battens

Position	Length	Roach	Angle	Luff	Leech	Full
100.000%	2.905m	0.050m	133.568?	13.793m	16.793m	Full
76.352%	3.271m	0.551m	91.281?	11.789m	12.821m	Full
60.591%	3.843m	0.535m	79.828?	9.764m	10.175m	Full
44.056%	4.383m	0.439m	79.828?	7.098m	7.398m	Full
23.794%	4.954m	0.282m	79.828?	3.833m	3.996m	Full
11.865%	2.216m	0.129m	79.828?	1.911m	1.992m	

#### Reefing Points

1, Luff: 2.435m ; Leech: 2.459m ; Offset: 0.000m ; Number Eyelets: 0  
2, Luff: 4.871m ; Leech: 4.917m ; Offset: 0.000m ; Number Eyelets: 0  
3, Luff: 9.470m ; Leech: 9.558m ; Offset: 0.000m ; Number Eyelets: 0

#### Luff Slides

1, Position: 0.765m  
2, Position: 1.529m  
3, Position: 2.288m  
4, Position: 3.135m  
5, Position: 5.124m  
6, Position: 6.079m  
7, Position: 7.966m  
8, Position: 8.909m  
9, Position: 10.419m  
10, Position: 11.126m  
11, Position: 12.854m  
12, Position: 15.189m

#### Luff Curve

		Fanned Luff (@ 5.00% [0.274m])	Before BSeam
16.249m,	0.000m	100% (16.250m) :	0.000m
14.225m,	-0.034m	90% (14.626m) :	0.069m
12.187m,	-0.058m	80% (13.000m) :	0.135m
10.145m,	-0.071m	70% (11.375m) :	0.167m
8.125m,	-0.073m	60% (9.750m) :	0.170m
6.055m,	-0.068m	50% (8.125m) :	0.158m
4.062m,	-0.054m	40% (6.500m) :	0.133m
2.025m,	-0.031m	30% (4.875m) :	0.102m
0.000m,	0.000m	20% (3.250m) :	0.066m
		10% (1.625m) :	0.030m
		0% (0.000m) :	0.000m

# Mainsail: 7000102 Christian square top main V1.des Michael

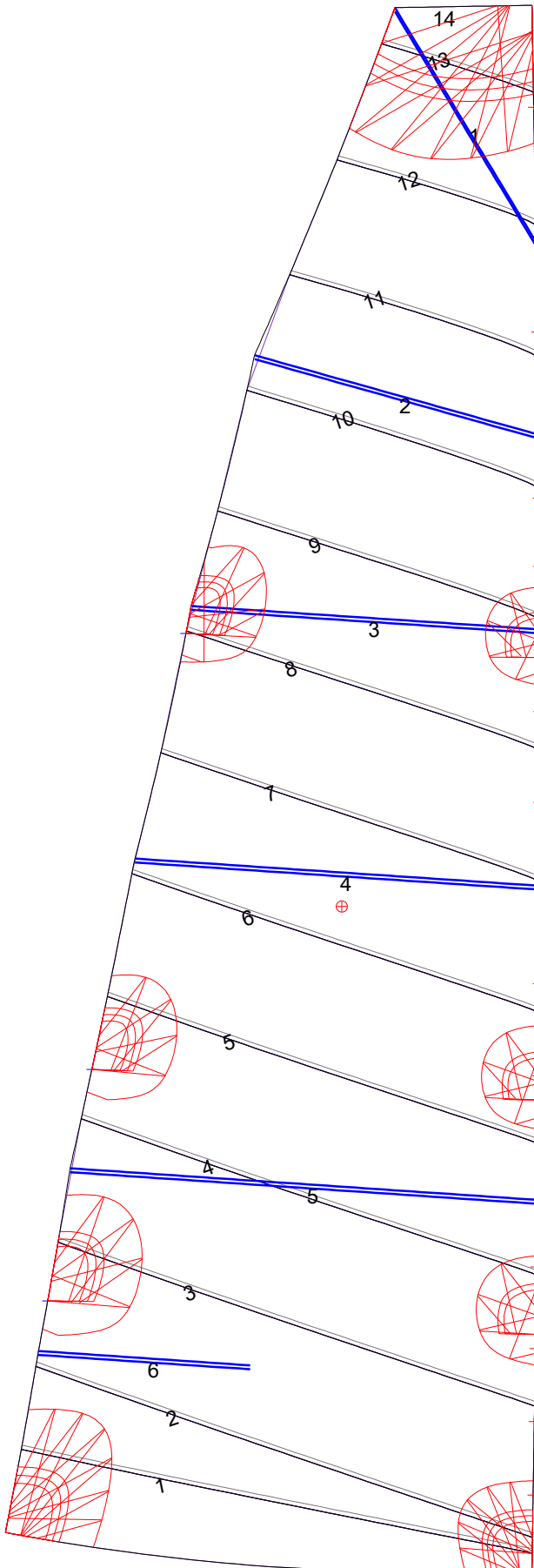

Seam Allowances			
Zone: 1	Split	Radial	Cross
	0.000m	0.000m	0.045m

Edge Excesses			
Sail:	Luff	Leech	Foot
	0.000m	0.000m	0.000m

Total Seam Lengths (m)

Horizontal	53.20
Radial/Vertical	0.00
Bi-Radial Split	0.00

Materials

Material	Area (m <sup>2</sup> )	Panels
Material 1	64.63	1,2,3,4,5 6,7,8,9,10 11,12,13,14